

1200V N-Channel Silicon Carbide Power MOSFET for Automotive



1. Applications

- Asymmetrical Bridge Converter
- Inverter
- Single Switch Forward Flyback

2. Features

- Low drain-source on-resistance: $R_{DS(ON)}=40m\Omega$ (typ.)
- Easy to control Gate switching
- Enhancement mode: $V_{th} = 2$ to $4V$
- AEC-Q101 qualified



Table 1 Key Performance Parameters

Parameter	Value	Unit
$V_{DS} @ T_{j,max}$	1200	V
$R_{DS(on),max}$	60	$m\Omega$
$Q_{g,typ}$	105	nC
$I_{D,pulse}$	152	A

3. Packaging and Internal Circuit

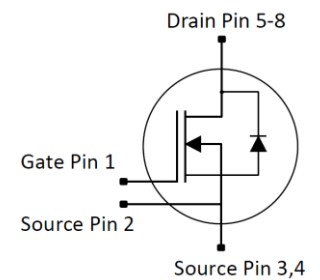
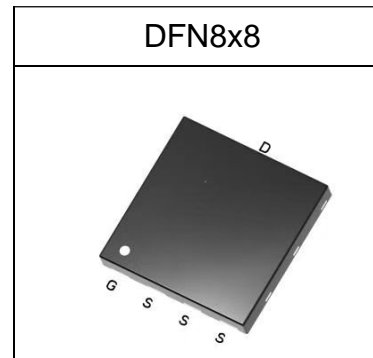
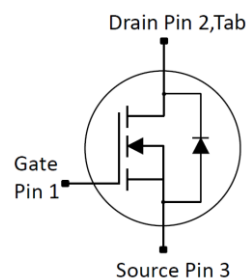
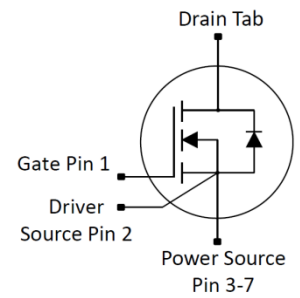
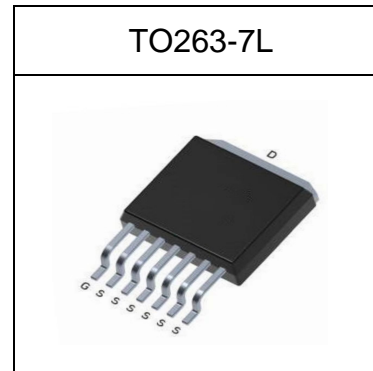
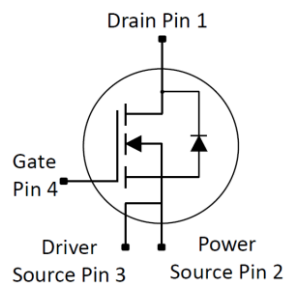

1 Maximum ratings

at $T_j = 25^\circ\text{C}$, unless otherwise specified

Table 2 Maximum ratings

Parameter	Symbol	Values			Unit	Note / Test Condition
		Min.	Typ.	Max.		
Continuous drain current ¹⁾	I_D	-	-	50.5	A	$T_C=25^\circ\text{C}$
		-	-	35	A	$T_C=100^\circ\text{C}$
Pulsed drain current ²⁾	$I_{D,pulse}$	-	-	152	A	$T_C=25^\circ\text{C}$
Avalanche energy, single pulse	E_{AS}	-	-	990	mJ	$T_C=25^\circ\text{C}, V_{DD}=50\text{V}, L=10\text{mH}, R_G=25\Omega$
Gate source voltage (dynamic)	V_{GS}	-10	-	22	V	Absolute maximum values
Gate source voltage (static)	V_{GS}	-5	-	20	V	Recommended operational values
Power dissipation	P_{tot}	-	-	273	W	$T_C=25^\circ\text{C}$
Storage temperature	T_{stg}	-55	-	175	$^\circ\text{C}$	
Operating junction temperature	T_j	-55	-	175	$^\circ\text{C}$	
Soldering Temperature Distance of 1.6mm from case for 10s	T_L			260	$^\circ\text{C}$	
Transconductance	GFS	-	19.5	-	S	VDS=20V IDS=33.3A
			29.6			VDS=20V IDS=33.3A, $T_j=175^\circ\text{C}$

2 Thermal characteristics

Table 3 Thermal characteristics

Parameter	Symbol	Values			Unit	Note / Test Condition
		Min.	Typ.	Max.		
Thermal resistance, junction - case	R_{thJC}	-	0.55	0.7	°C/W	-
Thermal resistance, junction - ambient	R_{thJA}	-	-	36	°C/W	device on PCB, minimal footprint

3 Electrical characteristics

 at $T_j=25^{\circ}\text{C}$, unless otherwise specified

Table 4 Static characteristics

Parameter	Symbol	Values			Unit	Note / Test Condition
		Min.	Typ.	Max.		
Drain-source breakdown voltage	$V_{(BR)DSS}$	1200	-	-	V	$V_{GS}=0V, I_D=100\mu A$
Gate threshold voltage	$V_{(GS)th}$	2	2.7	4	V	$V_{DS}=V_{GS}, I_D=5mA$
Zero gate voltage drain current	I_{DSS}	-	-	50	μA	$V_{DS}=1200V, V_{GS}=0V$
Gate-source leakage current	I_{GSS+}	-	-	250	nA	$V_{GS}=22V, V_{DS}=0V$
Gate-source leakage current	I_{GSS-}	-	-	-100	nA	$V_{GS}=-10V, V_{DS}=0V$
Drain-source on-state resistance	$R_{DS(on)}$	-	40	60	m Ω	$V_{GS}=20V, I_D=20A, T_j=25^{\circ}\text{C}$
			66			$V_{GS}=20V, I_D=20A, T_j=150^{\circ}\text{C}$
Gate resistance (Intrinsic)	R_G	-	5.2	-	Ω	$f=1MHz, \text{open drain}$

Table 5 Dynamic characteristics

Parameter	Symbol	Values			Unit	Note / Test Condition
		Min.	Typ.	Max.		
Input capacitance	C_{iss}	-	2530	-	pF	$V_{GS}=0V, V_{DS}=1000V, f=1MHz$
Output capacitance	C_{oss}	-	110.7	-	pF	
Reverse transfer capacitance	C_{rss}	-	7.02	-	pF	
Turn-on delay time	$t_{d(on)}$	-	57.71	-	ns	$V_{DD}=800V, I_D=33.3A, R_G=2.5\Omega;$ $T_j=25^{\circ}\text{C}$ $V_{GS}=-4/18V, L=99\mu H$
Rise time	t_r	-	15	-	ns	
Turn-off delay time	$t_{d(off)}$	-	36.56	-	ns	
Fall time	t_f	-	9.924	-	ns	
Turn-on Switching Energy	E_{on}		1079		μJ	
Turn-off Switching Energy	E_{off}		97.71		μJ	

Table 6 Gate charge characteristics

Parameter	Symbol	Values			Unit	Note / Test Condition
		Min.	Typ.	Max.		
Gate to source charge	Q_{gs}	-	33.8	-	nC	$V_{DD}=800V, I_D=30A, V_{GS}=-4/18V$
Gate to drain charge	Q_{gd}	-	34.1	-	nC	
Gate charge total	Q_g	-	105	-	nC	

Table 7 Reverse diode characteristics

Parameter	Symbol	Values			Unit	Note / Test Condition
		Min.	Typ.	Max.		
Continuous Source Current	I_{SD}	-	-	50.5	A	
Diode forward voltage	V_{SD}	-	3.6	-	V	$I_S = 20A, V_{GS} = 0V, T_j = 25^\circ C$
Reverse recovery time	t_{rr}	-	37.23	-	ns	$V_{GS} = -4 V, I_{SD} = 33.3 A,$ $VR = 800 V$ $di/dt = 1150 A/\mu s, T_j = 175^\circ C$
Reverse recovery charge	Q_{rr}	-	707.6	-	nC	
Peak reverse recovery current	I_{rrm}	-	30.55	-	A	

4 Electrical characteristics diagram

Diagram 1: Typ. output characteristics

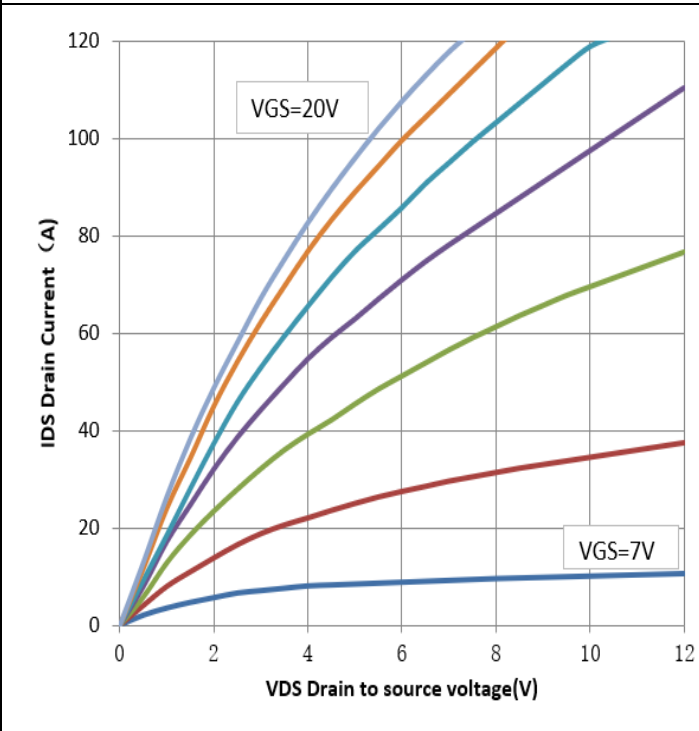

$I_D=f(V_{DS}); T_j=25^\circ\text{C}$; parameter: V_{GS} ; $V_{GS}=7,9,11,13,15,18,20\text{V}$

Diagram 2: Typ. output characteristics

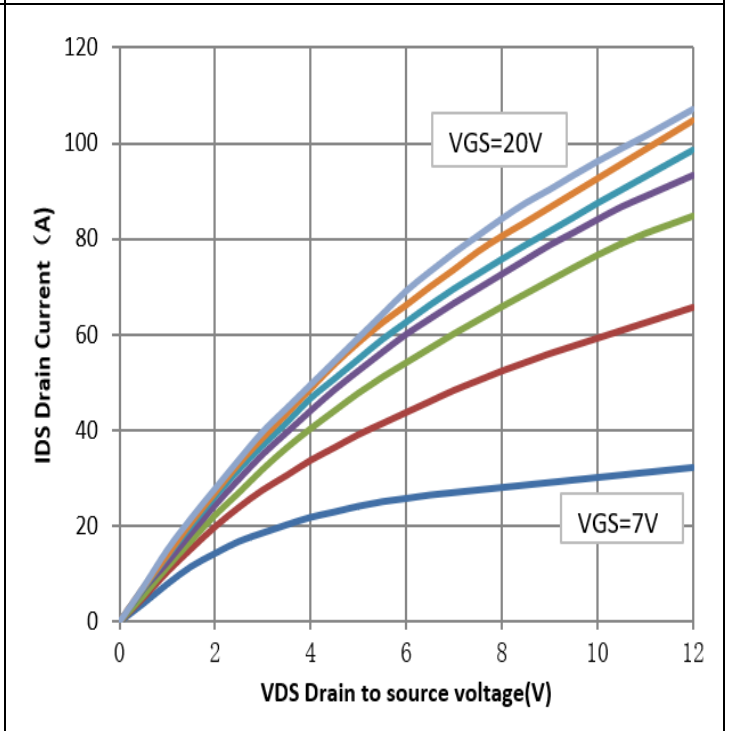

$I_D=f(V_{DS}); T_j=175^\circ\text{C}$; parameter: V_{GS} ; $V_{GS}=7,9,11,13,15,18,20\text{V}$

Diagram 3: Typ. transfer characteristics

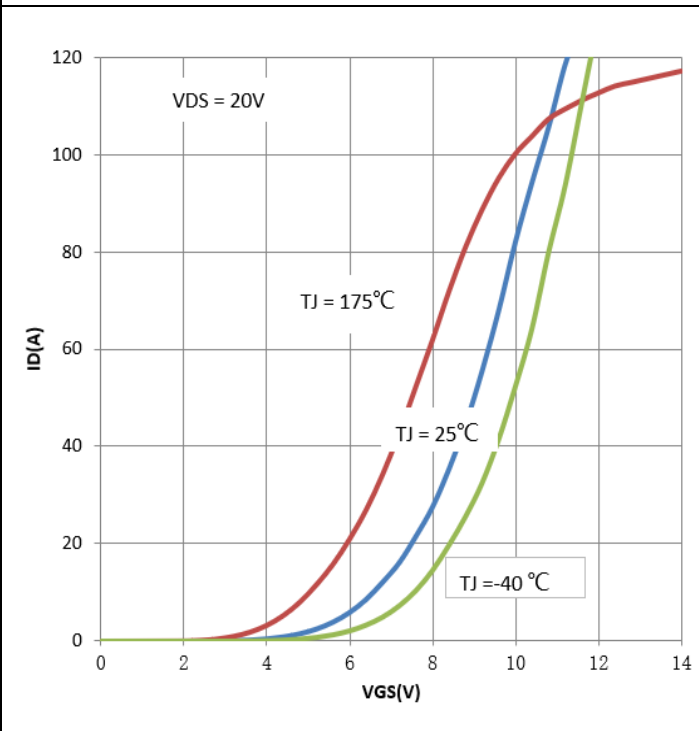

$I_D=f(V_{GS}); V_{DS} = 20\text{V}$; parameter: T_j

Diagram 4: Typ. gate charge

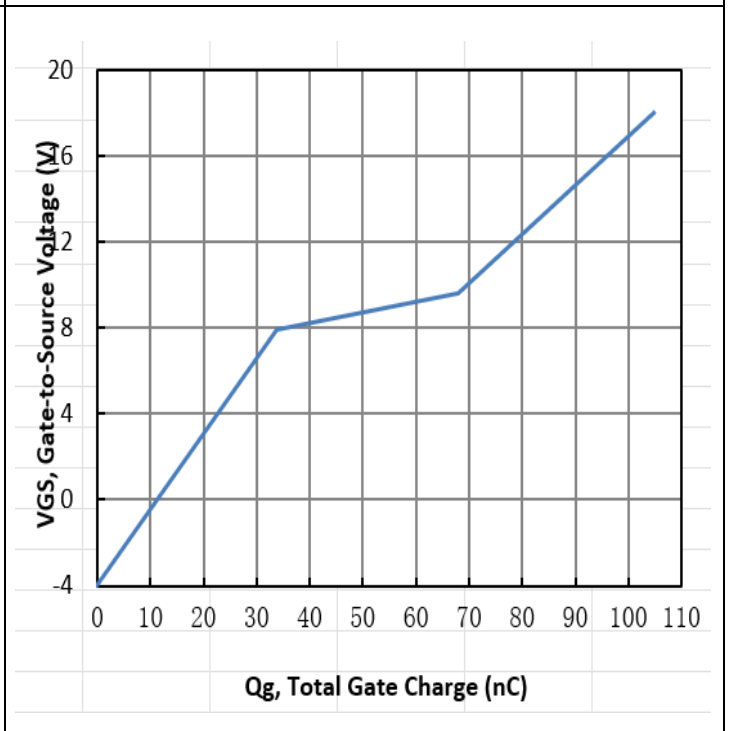

$V_{GS}=f(Q_{gate}); I_D=30\text{A}; V_{DS} = 800\text{V}$; turn-on pulse

Diagram 5: Typical gate-source threshold voltage as a function of junction temperature

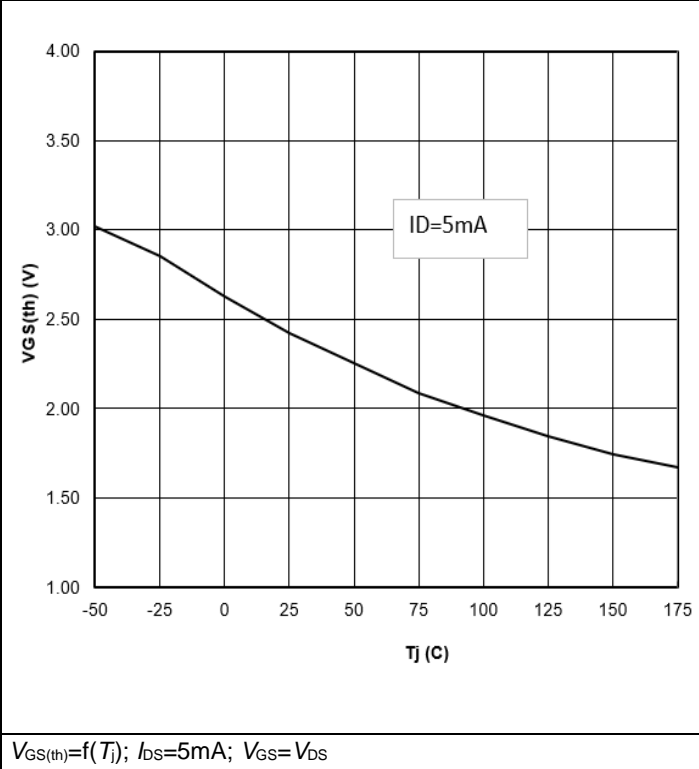

Diagram 6: Typ. Capacitance as a function of drain-source voltage

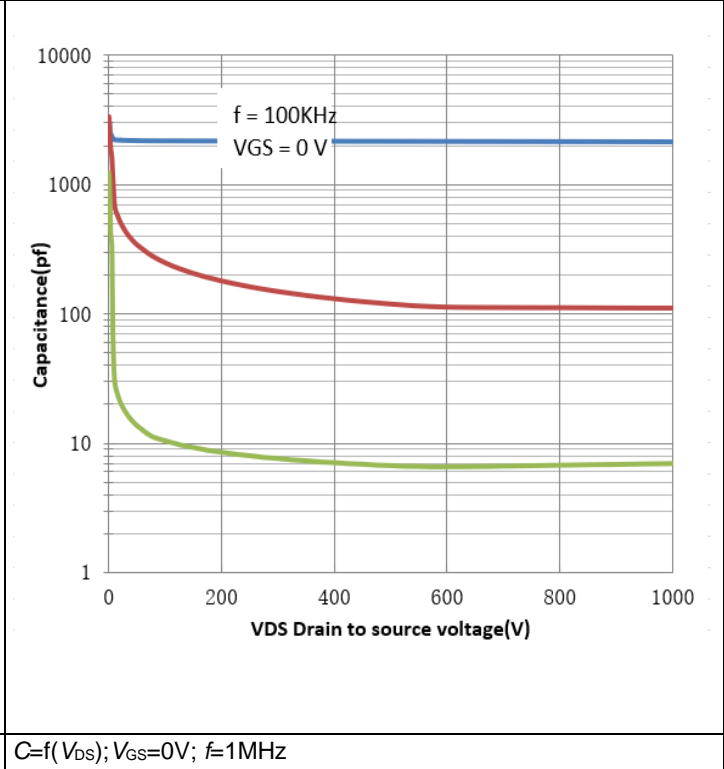

Diagram 7: Normalized on-resistance vs. junction temperature

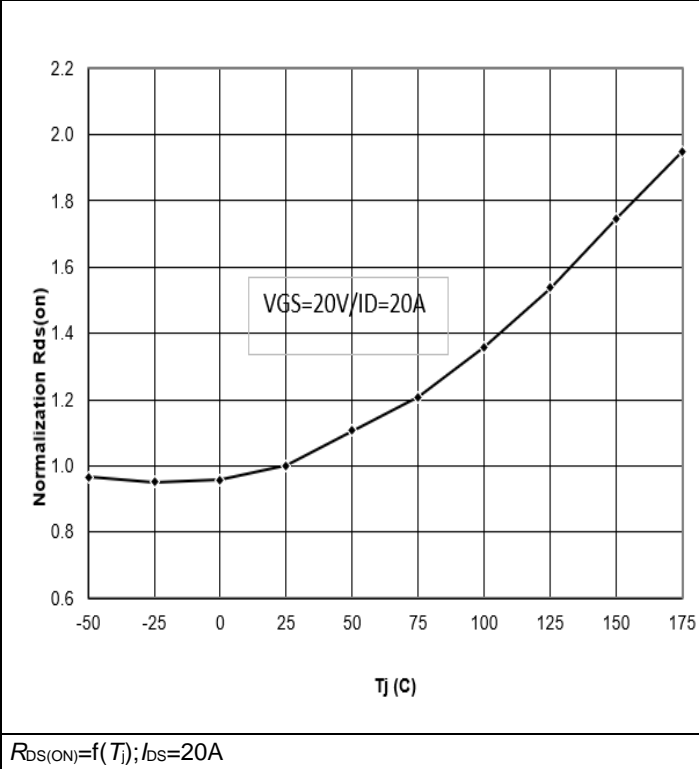

Diagram 8: Typical body diodes Characteristics at 25°C

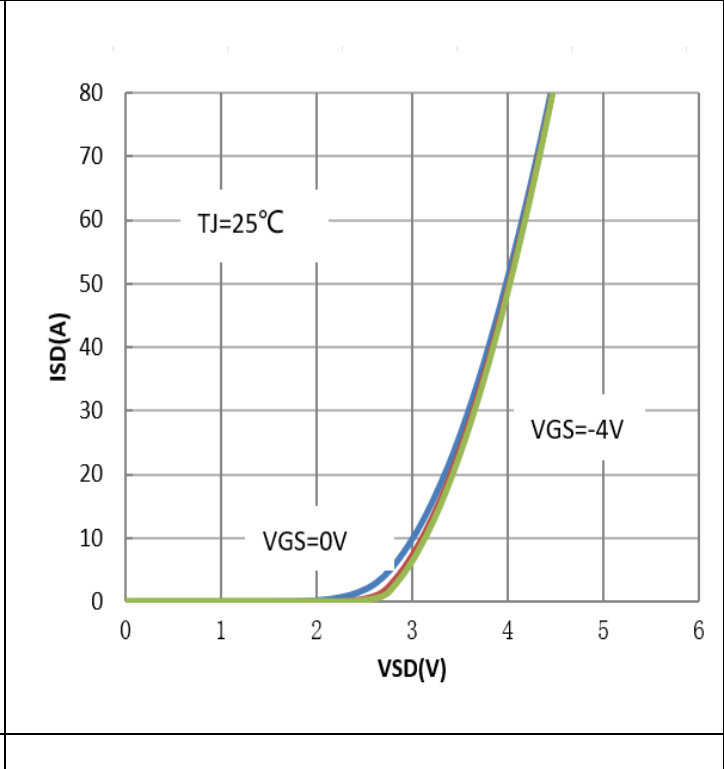
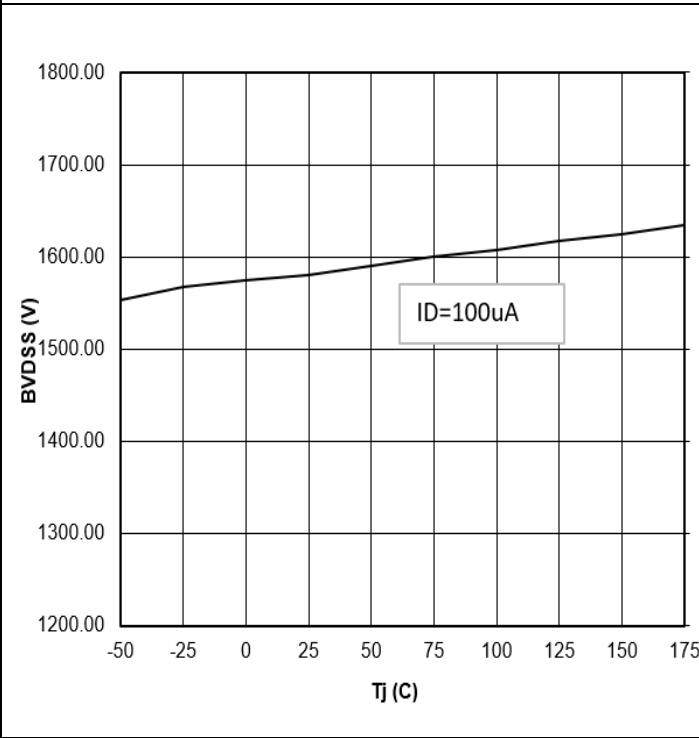
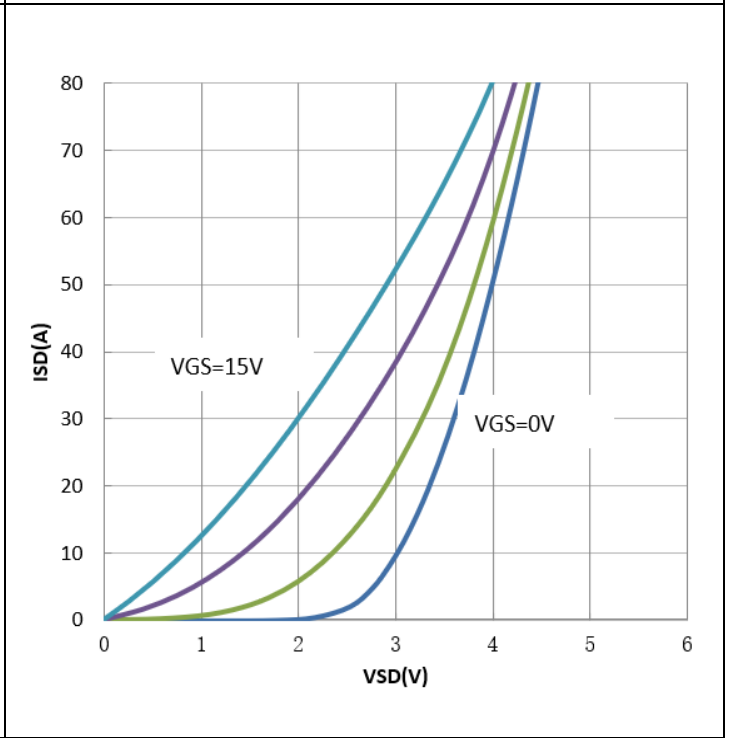

Diagram 9: BVDSS VS junction temperature



$B_{vdss}=f(T_j)$

Diagram 10: 3rd Quadrant Characteristic at 25 °C



$I_{SD}=f(V_{SD})$

Diagram 11: Safe operating area(SOA)

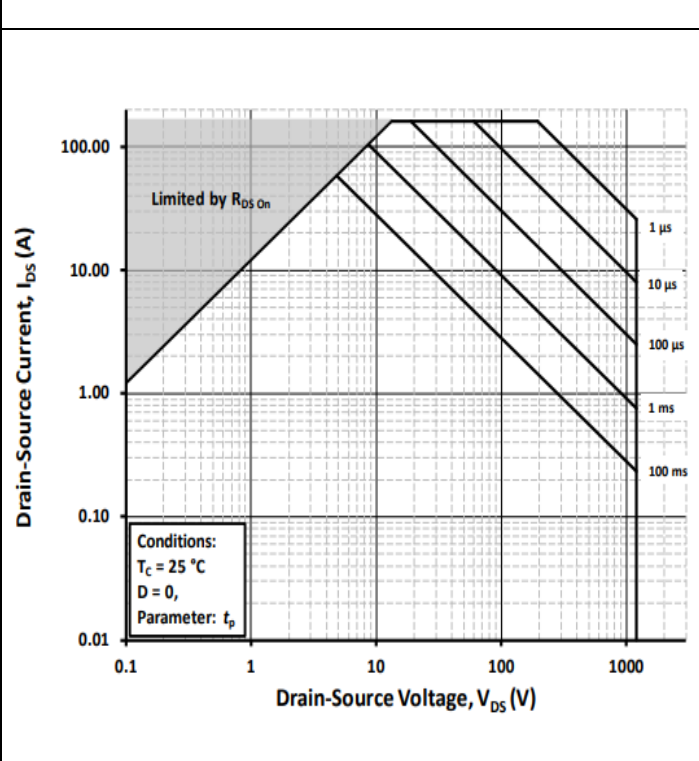

$V_{GS}=0/18V; T_C=25\ ^\circ C; T_j<175\ ^\circ C$

Diagram 12: Power dissipation as a function of case temperature limited by bond wire

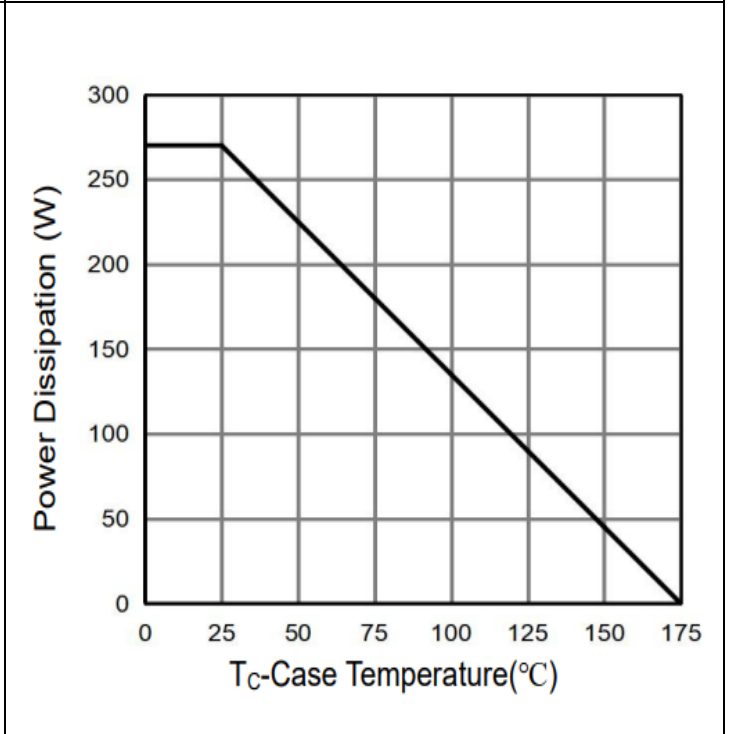

$P_{tot}=f(T_C)$

Diagram 13: Clamped Inductive Switching Energy vs. Drain Current (VDD = 800V)

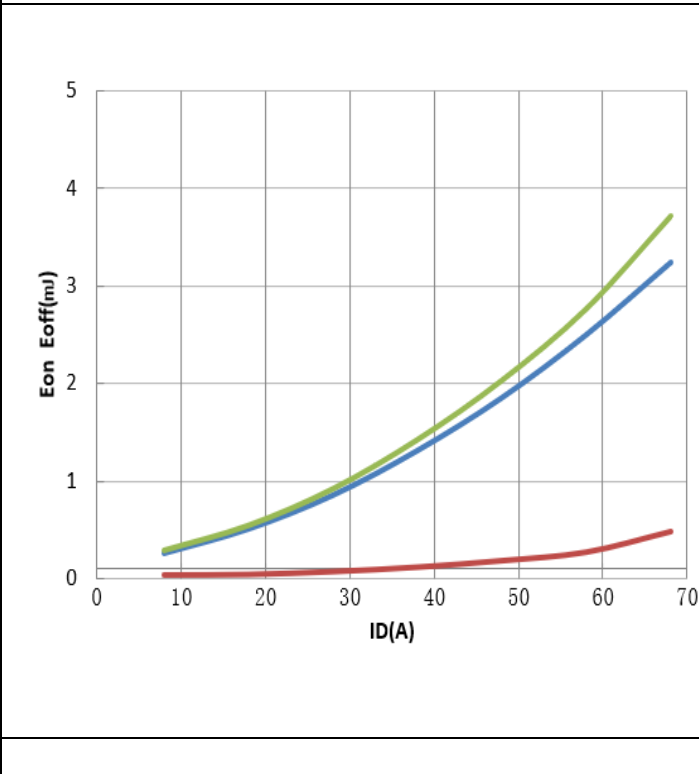

Diagram 14: Clamped Inductive Switching Energy vs. RG(ext)

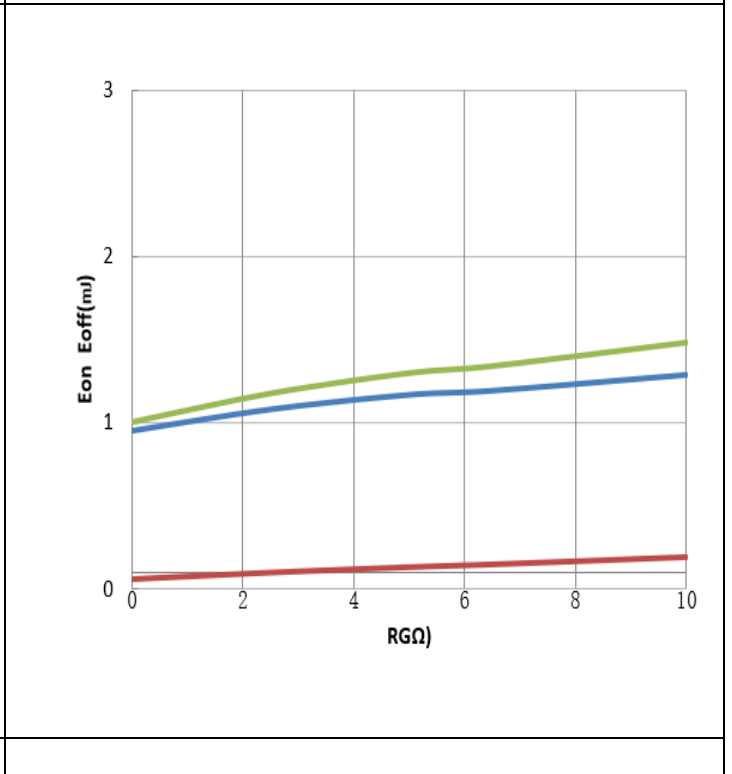

Diagram 15: Clamped Inductive Switching Energy vs. Temperature

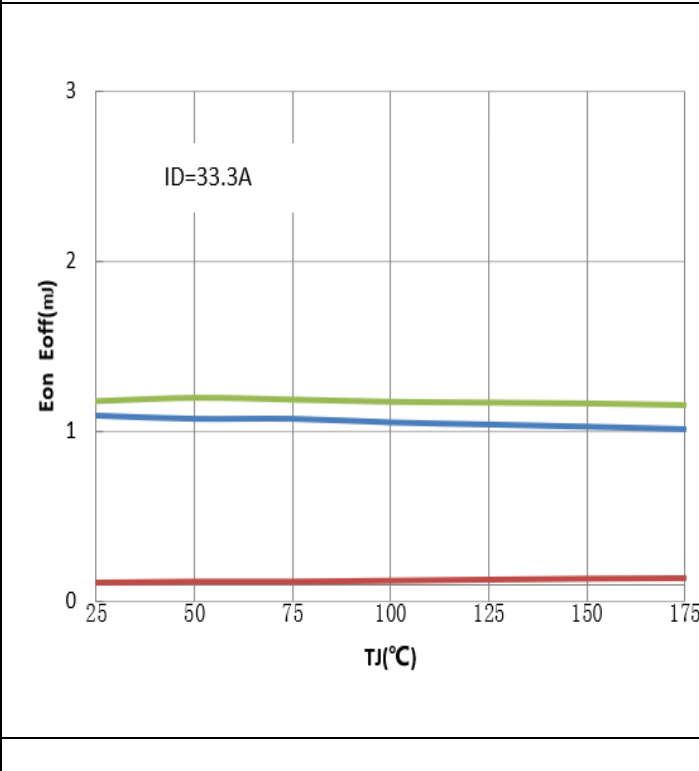

Diagram 16: Switching Times vs. RG(ext)

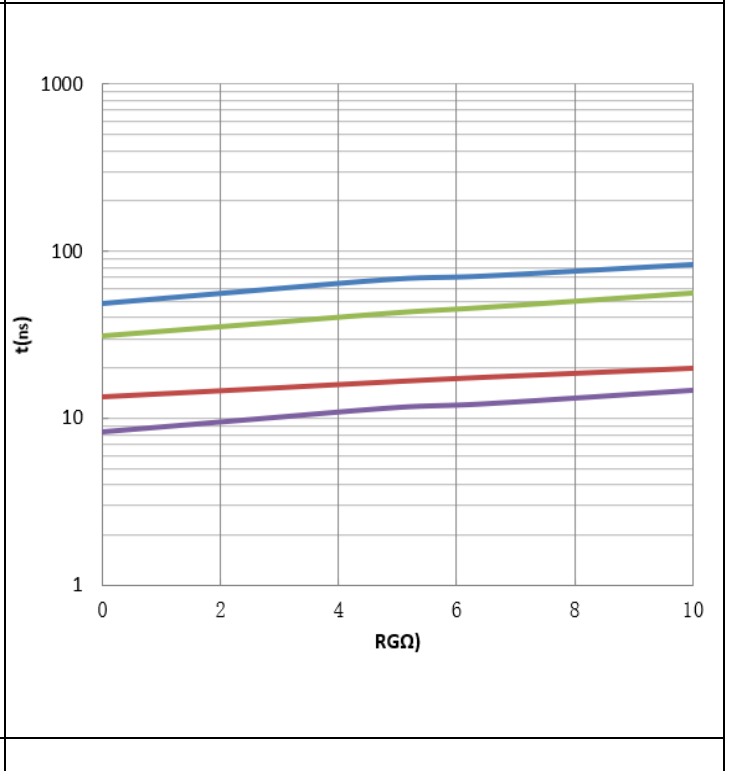
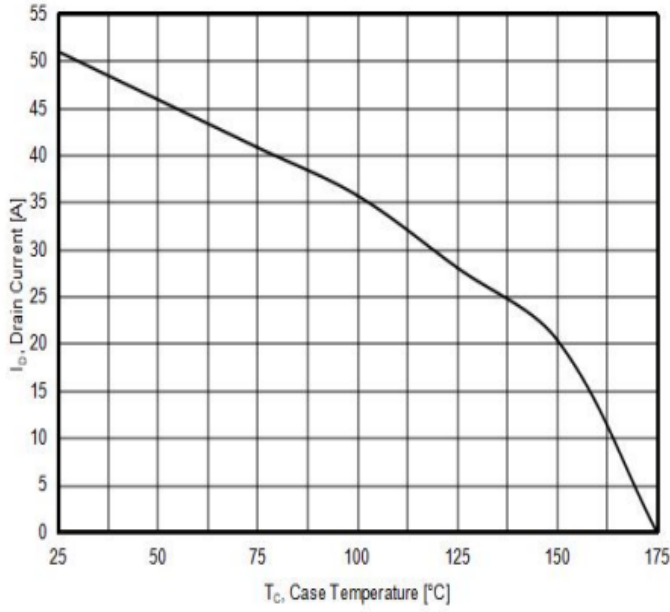
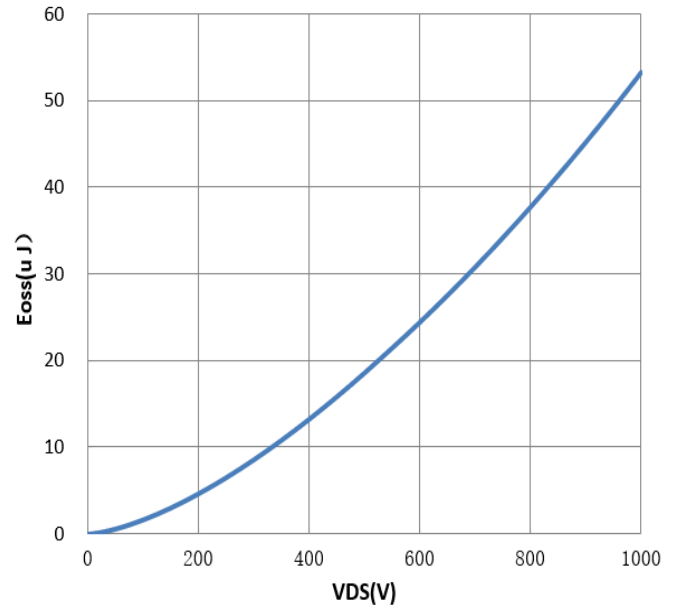

Diagram 17: Continuous Drian Current Derating vs. Case Temperature



$$I_{DS} = f(T_C)$$

Diagram 18: Output Capacitor Stored Energy



$$E_{oss} = f(V_{DS})$$

Diagram 19: Max. transient thermal resistance(MOSFET/diodes)

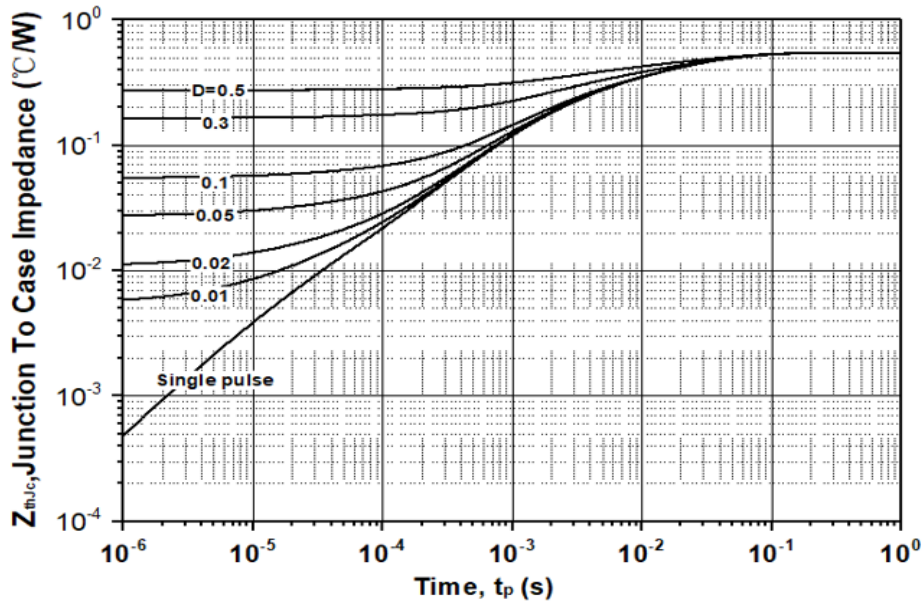

$$Z_{th(j-c,max)} = f(t_p), \text{ parameter } D = t_p / T$$

5 Test Circuits

Table 8 Diode characteristics

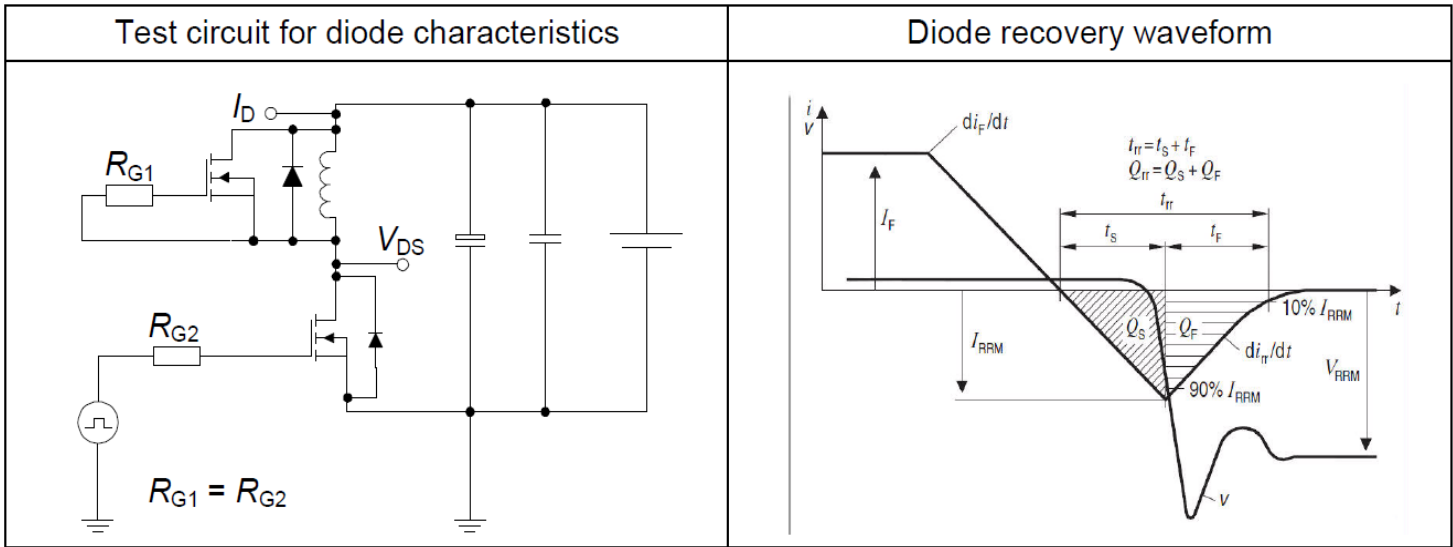
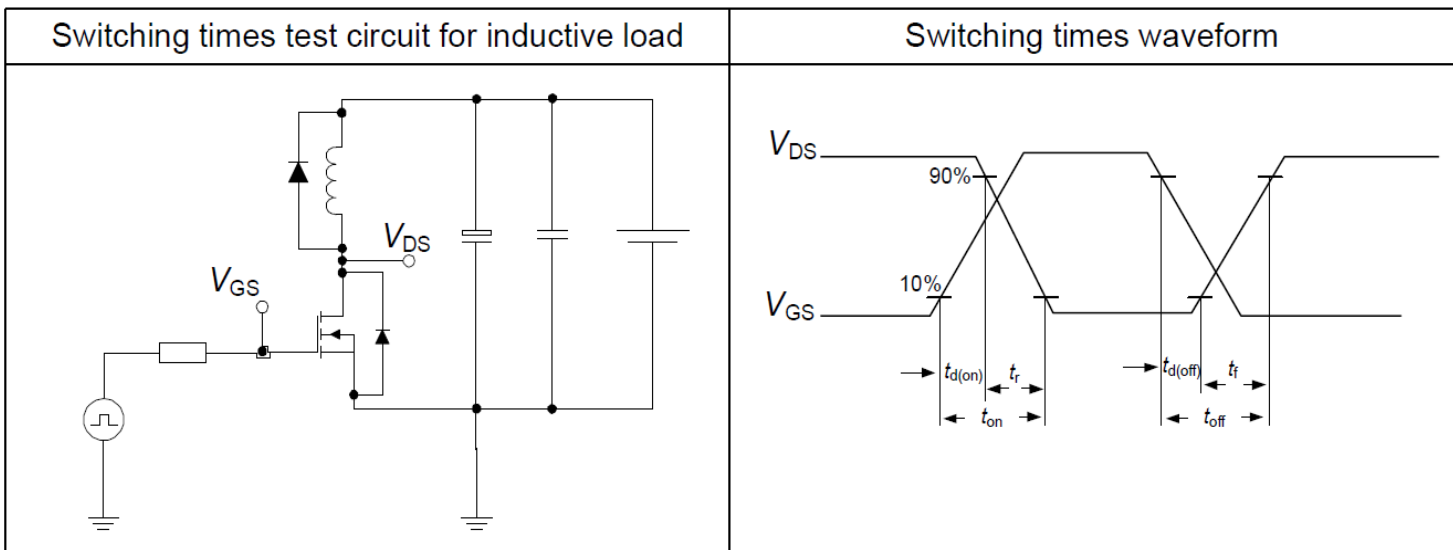
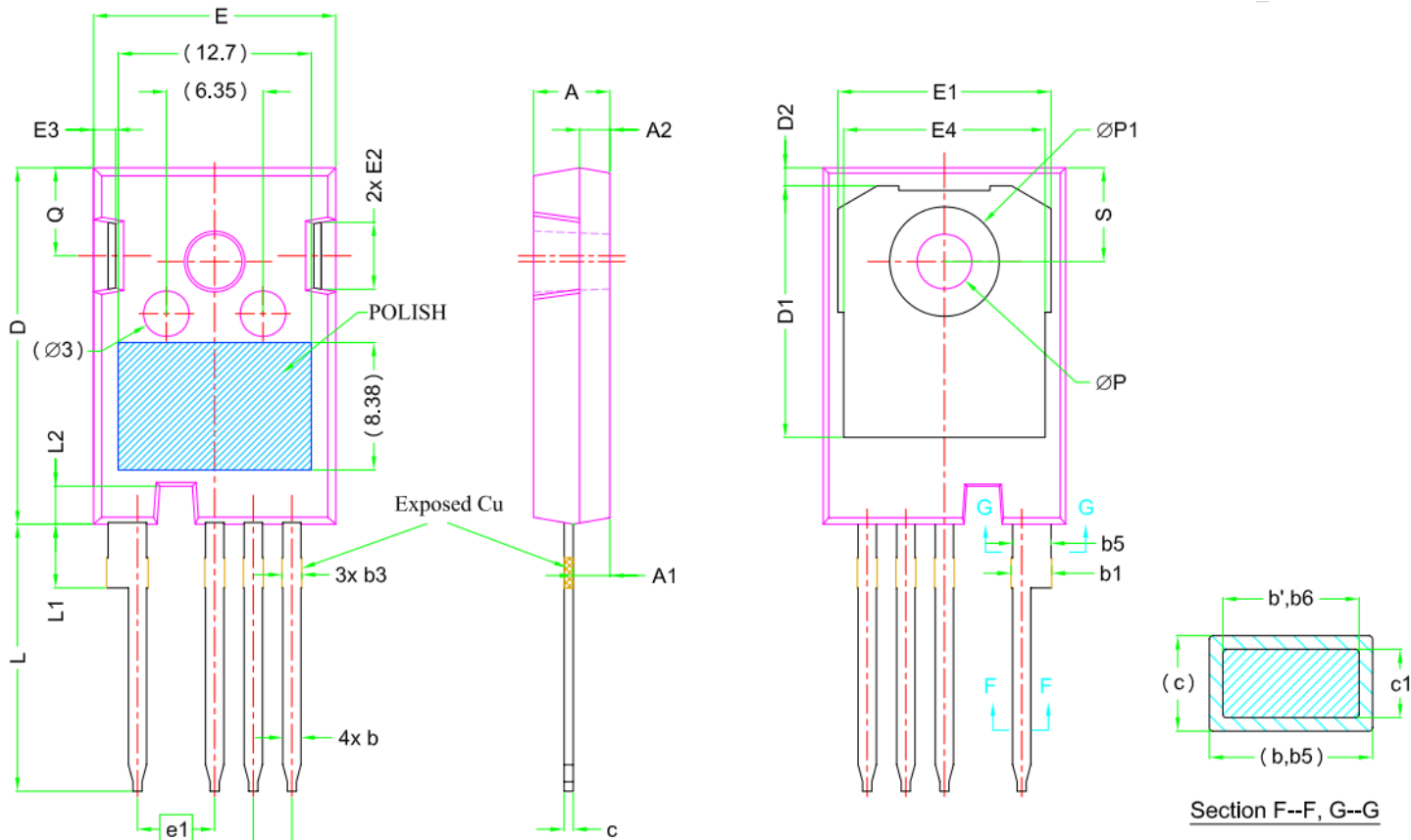

Table 9 Switching times



6 Package Outlines

TO-247-4L



SYMBOL	DIMENSIONS		
	MIN.	NOM.	MAX.
A	4.83	5.02	5.21
A1	2.29	2.41	2.54
A2	1.91	2.00	2.16
b'	1.07	1.20	1.28
b	1.07	1.20	1.33
b1	2.39	2.67	2.94
b2	2.39	2.67	2.84
b3	1.07	1.30	1.60
b4	1.07	1.30	1.50
b5	2.39	2.53	2.69
b6	2.39	2.53	2.64
c	0.55	0.60	0.68
c1	0.55	0.60	0.65
D	23.30	23.45	23.60
D1	16.25	16.55	17.65
D2	0.95	1.19	1.25
E	15.75	15.94	16.13
E1	13.10	14.02	14.15
E2	3.68	4.40	5.10
E3	1.00	1.45	1.90
E4	12.38	13.26	13.43
e	2.54 BSC		
e1	5.08 BSC		
L	17.31	17.57	17.82
L1	3.97	4.19	4.37
L2	2.35	2.50	2.65
ΦP	3.51	3.61	3.65
ΦP1	7.19 REF		
Q	5.49	5.79	6.00
S	6.04	6.17	6.30

TO-247-3L

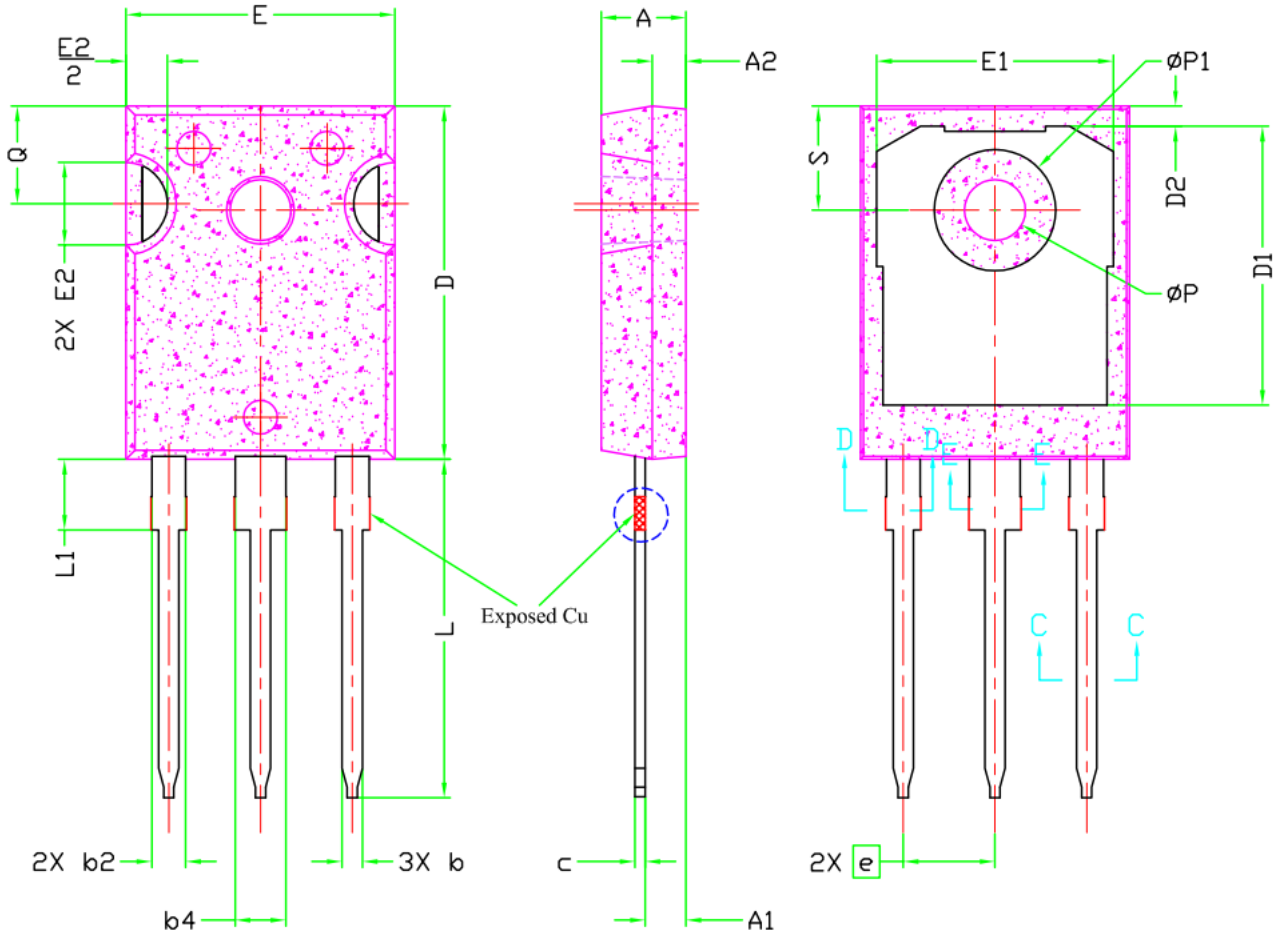

SYMBOL	DIMENSIONS			NOTES
	MIN.	NOM.	MAX.	
A	4.83	5.02	5.21	
A1	2.29	2.41	2.55	
A2	1.50	2.00	2.49	
b	1.12	1.20	1.33	
b1	1.12	1.20	1.28	
b2	1.91	2.00	2.39	6
b3	1.91	2.00	2.34	
b4	2.87	3.00	3.22	6,8
b5	2.87	3.00	3.18	
c	0.55	0.60	0.69	6
c1	0.55	0.60	0.65	
D	20.80	20.95	21.10	4
D1	16.25	16.55	17.65	5
D2	0.51	1.19	1.35	
E	15.75	15.94	16.13	4
E1	13.46	14.02	14.16	5
E2	4.32	4.91	5.49	3
e	5.44BSC			
L	19.81	20.07	20.32	
L1	4.10	4.19	4.40	6
ΦP	3.56	3.61	3.65	7
ΦP1	7.19REF			
Q	5.39	5.79	6.20	
S	6.04	6.17	6.30	

TO-263-7L(RYX)

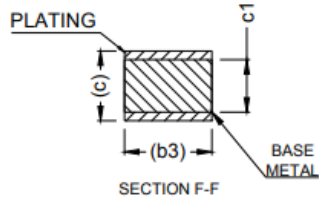
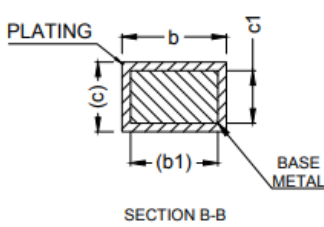
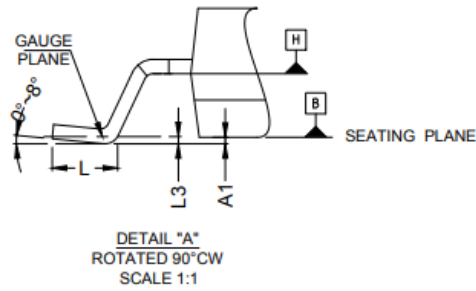
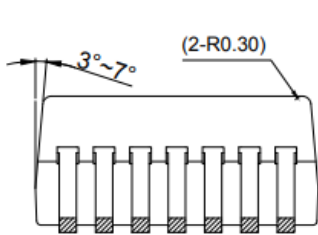
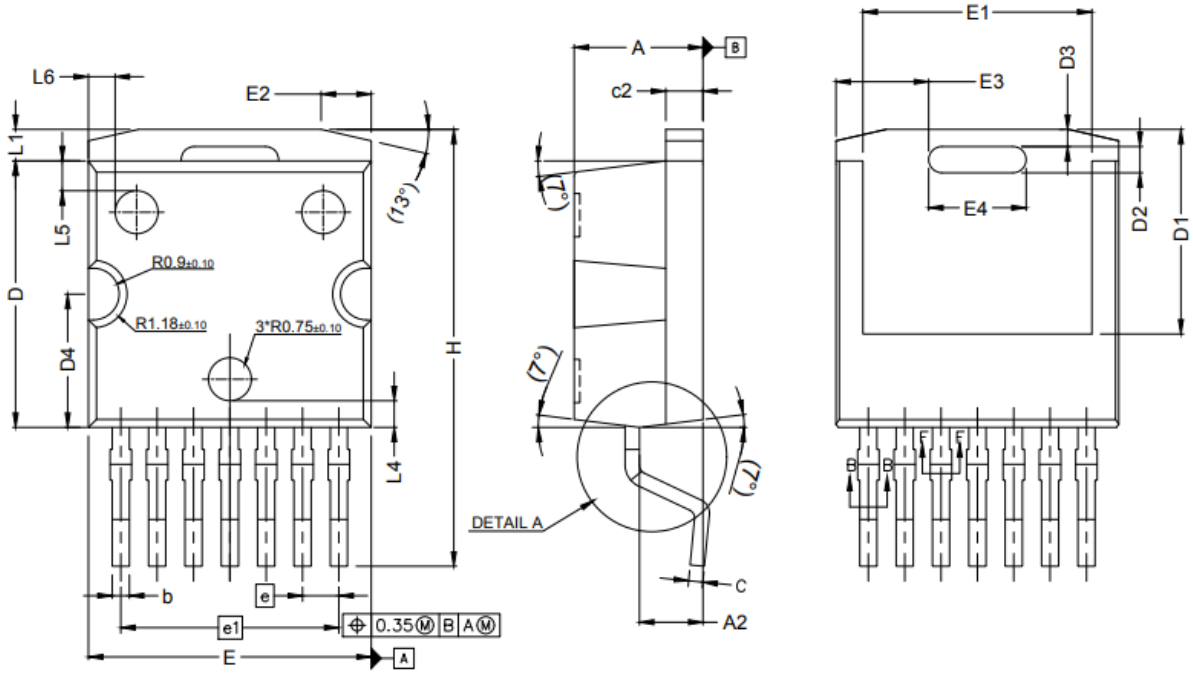

SYMBOL	MIN	MAX	SYMBOL	MIN	MAX
A	4.30	4.70	E	9.68	10.08
A1	-	0.25	E1	7.70	8.30
A2	2.02	2.42	E2	1.55	1.95
b	0.50	0.70	E3	3.04	3.44
b1	0.50	0.65	E4	3.21	3.61
b3	0.60	0.75	e	1.27 BSC	
c	0.45	0.60	e1	7.62 BSC	
c1	0.45	0.55	L	1.78	2.79
c2	1.25	1.40	L1	-	1.60
D	9.10	9.50	L3	0.25BSC	
D1	6.86	7.42	L4	0.93BSC	
D2	0.72	1.12	L5	1.04BSC	
D3	0.40	0.80	L6	0.93BSC	
D4	4.45	4.85	H	14.61	15.88

DFN8X8(RYX)

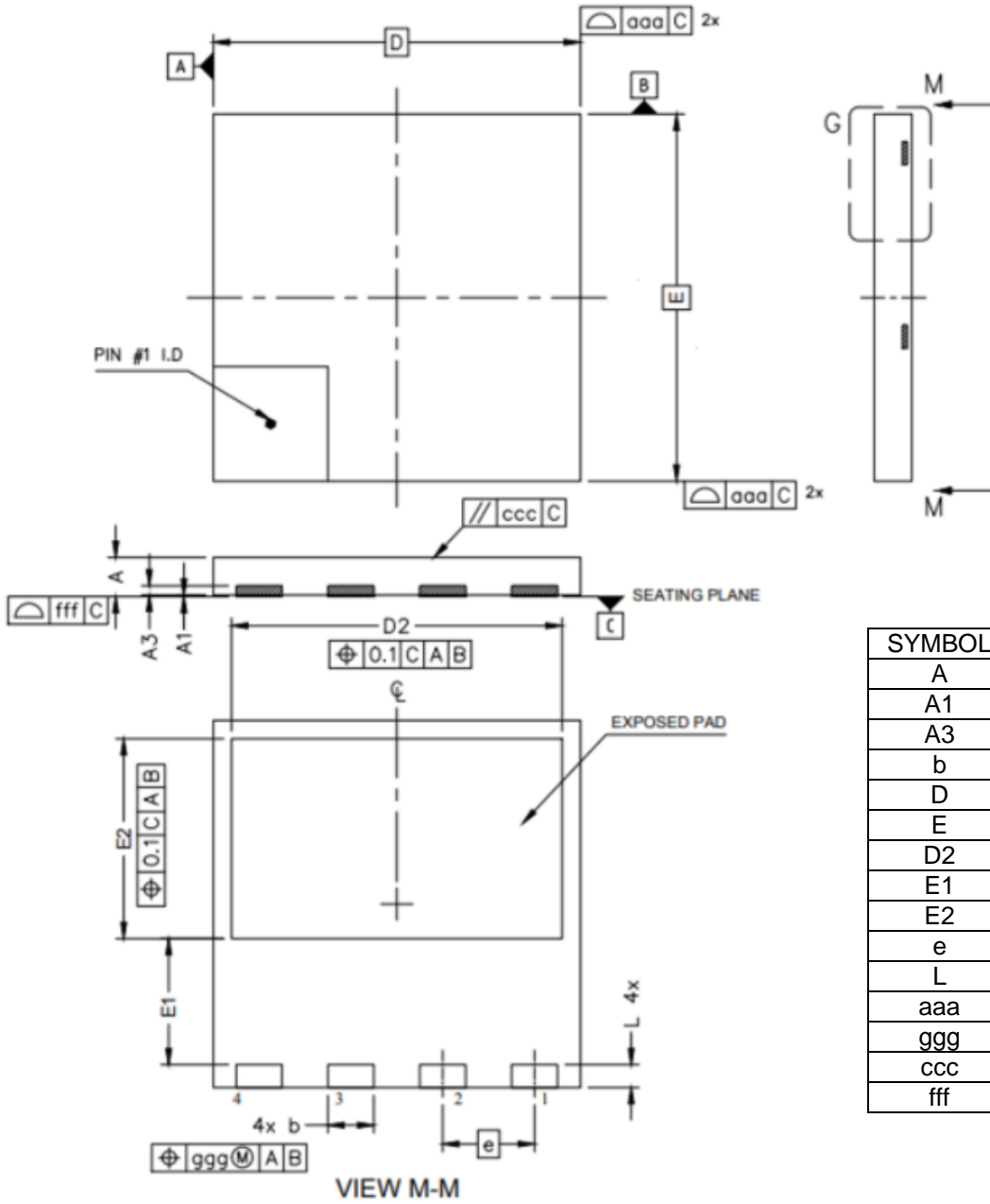

SYMBOL	MIN	MAX
A	0.75	0.95
A1	0.00	0.05
A3	0.10	0.30
b	0.90	1.10
D	7.90	8.10
E	7.90	8.10
D2	7.10	7.30
E1	2.65	2.85
E2	4.25	4.45
e	2.00BSC	
L	0.40	0.60
aaa	0.10	
ggg	0.05	
ccc	0.05	
fff	0.05	